



**Scottish
Forestry**
Coilltearachd
na h-Alba

Central Scotland Conservancy
Bothwell House, Hamilton Business Park, Caird Park
Hamilton ML3 0QA

Email: centralscotland.cons@forestry.gov.scot
Tel: 0300 067 6006

Conservator
Keith D Wishart FICFor

Monday 25th November 2019

Planning Department
East Lothian Council
John Muir House,
Brewery Park,
Haddington,
East Lothian, EH41 3HA.

Our Ref: S6-1-25-18-19
Planning Reference: **19/00895/P**

Sent to Environment@eastlothian.gov.uk

Dear Sir/Madam

19/00895/P | Change of use of agricultural land to domestic garden ground and extension to house, erection of 1 house, conversion, extensions to agricultural buildings to form 2 houses, erection of triple domestic garage/store, greenhouse and associated works | Broad Sands House Dirleton North Berwick East Lothian EH39 5EN

Scottish Forestry would like to thank you for the opportunity to provide comments on the above planning application.

Scottish Forestry

Scottish Forestry is a closed in Executive Agency of Scottish Government and serves to protect and expand Scotland's forests and woodlands on behalf of Scottish Ministers for the benefit of the Scottish people. With respect to these responsibilities Scottish Forestry has an interest in all developments that have the potential to impact on local forests and woodlands and/or the forestry sector. Scottish Forestry (SF), as the Authority and Regulator with regard to the sustainable management of forests and woodland and holding Key Agency Status, should be consulted with on any development proposal that seeks to make changes to woodland environs. This is to ensure that the proposals are appropriate, address the requirements of the Scottish Governments Control of Woodland Removal Policy and are carried out in accordance with the UK Forestry Standard.

Consultation Comments

The main issue of concern to SF in relation to this particular development application is that of development deforestation. Scottish Planning Policy paragraph 218, issued by the Scottish Government, refers to the Control of Woodland Removal Policy which seeks to protect the existing forest resource in Scotland, and supports woodland removal only where it would achieve significant and clearly defined additional public benefits. A proposal for compensatory planting may form part of any determination.

Scottish Forestry is the Scottish Government agency responsible for forestry policy, support and regulation



Scottish Government
Riaghaltas na h-Alba
gov.scot

S e Coilltearachd na h-Alba a' bhuidheann-ghnìomha aig Riaghaltas na h-Alba a tha an urra ri poileasaidh, taic agus riaghladh do choilltearachd

With regards to development proposal 19/00895/P, specifically to House 4 as seen in CGI House 04B, the Authority should be aware that this area is currently part of an ongoing investigation into a proposed Illegal felling. We would advise the Authority that a Restocking Direction which is a Legal Direction issued by Scottish Forestry on behalf of Scottish Ministers to replant the area deforested, was issued to the Owner via their Solicitor on Friday 15th November 2019.

It is with this in mind that Scottish Forestry would not be in support of the planning application relating to House 4. However as long as the Tree Report recommendations and BS 5837 Trees in relation to Design, Demolition and Construction Recommendations are adhered too in the construction of Houses 1-3, we would not have any objections to that part of the development.

If you would like to discuss any points raised further, please do not hesitate to contact us.

Your Sincerely

Redacted

Redacted Redacted Redacted

Regulations & Development Manager
Scottish Forestry

Enc:
Restocking Direction location Map,
Photographs of the area of deforestation at location House 4
CGI House 04B



Scottish Forestry / Coilltearachd na h-Alba

Annex 1 Restocking Direction Map

SFDIRO10 Dirleton New Mains

Compartment: 1
Grid Ref.: NT 5153 8467
Area: 0.17ha



Scale: 1:1,250 @ A4

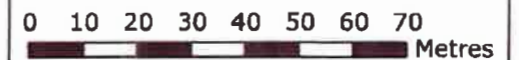

© Crown copyright and database right 2019.
Ordnance Survey Licence number 100043970.



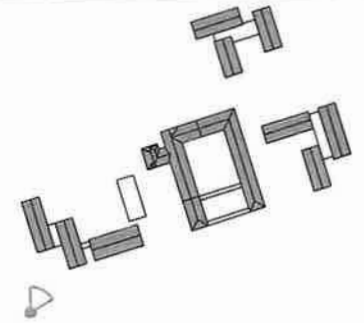

0131 2190077 contact@kholm.co.uk www.kholm.co.uk	NTS		BROAD SANDS HOUSE / DIRLETON / EAST LOTHIAN	PROJECT 003	
	A3		PROPOSED / CGI / HOUSE 04 / IMAGE B	003-PL-062	